

Jet Afterburner Simulator NF-Jet2

Description:

The **NF-Jet2** module serves to simulate flame on the output of the jet engine using red and yellow ultra bright LEDs (Light-Emitting Diodes) 3 or 5 mm. The input of the module has to be connected in parallel with the engine controller. Then intensity of the flame follows the power of the engine. First color starts to light at the beginning of "gas" range. The second color starts on the middle of the range. To increase the reality of the flame the light intensity changes in pseudo-random period. The frequency of changes speeds up when increasing the engine power.

The module has two sets of outputs and can power lights for one or two engines. The outputs can be also connected in parallel (Red1 to Red2 and Yellow1 to Yellow2) to power one engine with doubled light intensity.

The module is connected to receiver by a Graupner, Hitec type connector. There is an "Y" cable diverging build in the module to simplify connection of two engine controllers. Connectors are under the light ring connectors. The module can also be connected as an uncontrolled unit when disconnecting the cable to a receiver. In this case the light intensity is 100% (full gas).

The module has two outputs for light rings. Each output drives two colors. Usually the first color is red and the second one is yellow. The wires use the same color system. The brown wire in the middle is ground. This is a common negative pole of LEDs (cathodes) for both colors. The total current of one color ranges from 0 to 40 mA depending up the input signal and up the number of LEDs.

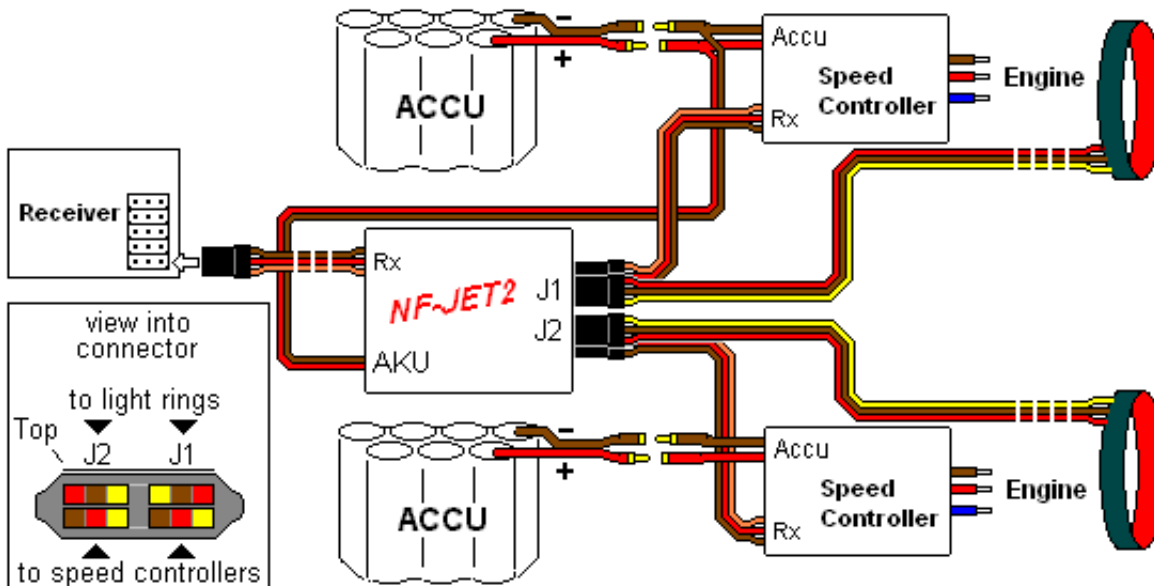

ATTENTION, the output connector has not a direction lock against change of polarity. If you turn the "light" connector only the order of colors will change.

The module NF-Jet2 is optimized to work with LED belts NF-Jet5 (eventually NF-Jet1) having one range of LEDs 3 or 5mm. NF-Jet5 belts are produced in three variants. The mini-version contains one range of LEDs 3 mm. The middle version contains two ranges of LEDs 3 mm and the big version contains two ranges of LEDs (internal range has LED 3mm and the external one 5mm). The mini belts are up to 258 mm (10.15 inches) long. NF-Jet5 belts are produced on demand. The NF-Jet1 belts can be modified by user. If the belt is turned so that the last segment is placed on the first free segment (without LEDs) You will have a circle with diameter 75 mm (3 inches). See the picture below. The circle can be fixed either by screws in holes **A** or by soldering of **B** points together. If You need a smaller circle you can shorten the belt by cutting of one or more segments along the line **C**. Each segment represents 5 mm (0,2 inches) of circle diameter. Diameter marks (in mili-meters **D** and in inches **E**) are placed beside the hole **A**. You obtain the circle of a required diameter when the mark (and the hole) of the segment with the requested diameter is placed onto "zero" mark (and the hole) on a first free segment.

Technical parameters :	min.	typ.	max.
Operation voltage:	6V	8,0V	14,0 V
Consumption of unit:		< 1.7 mA	
Output current:		max 80 mA per output	
Operational temperature:		0 - 70°C	
Dimensions of unit:		56 x 24 x 6 mm	
Weight of unit :		10.5 g	
Input pulse width:		0,95 ms – 2,05 ms	

Production:

Ivan Pavelka
 K Roztokům 65
 165 00 Praha 6 – Suchbátov
 Czech Republic

i.pavelka@volny.cz
 tel.: (+420) 605 404 499
 fax: (+420) 220 921 744
www.nightfly.cz

